



UNIVERSAL EDUCATION CENTRE (New Delhi)

JAYANT SHARMA (94145-37474)

www.uecj4u.hpage.co.in

SUMMATIVE ASSESSMENT – I

SCIENCE

Class – X

Time allowed: 3 hours

Maximum Marks: 90

General Instructions:

- (i) All questions are compulsory.
- (ii) The question paper comprises of two sections, A and B. You are to attempt both the sections.
- (iii) Questions 1 to 4 in section A are one mark questions. These are to be answered in one word or in one sentence.
- (iv) Questions 5 to 11 in section A are two marks questions. These are to be answered in about 30 words each.
- (v) Questions 12 to 23 in section A are three marks questions. These are to be answered in about 50 words each.
- (vi) Questions 24 to 27 in section A are five marks questions. These are to be answered in about 70 words each.
- (vii) Questions 28 to 43 in section B are multiple choice questions based on practical skills. Each question is a one mark question. You are to select one most appropriate response out of the four provided to you.

SECTION-A

1. What happens when ZnCO_3 is heated in the absence of air? Give the relevant equation.
2. Which gas is usually liberated when an acid reacts with a metal ?
3. Thermal power plants are setup near coal or oil fields. Give reason.
4. Why do we use copper and Aluminium wire for transmission of electric current ?
5. Write chemical equations for the reactions taking place when
 - (i) zinc sulphide is heated in air
 - (ii) calcination of zinc carbonate is done.
6. Write observation with reaction for the following : Granulated zinc reacts with dil. sulphuric acid.
7. "Respiration is an exothermic reaction." Justify this statement giving the chemical equation for the reaction involved.
8. The colour of copper sulphate solution changes when an iron nail is dipped in it. State the reason giving chemical equation for the reaction involved.
9. Which is the internal energy reserve in plants? Do the animals have the same energy reserve ? Justify your answer.
10. Differentiate between renewable and non-renewable sources of energy with one example for each.
11. Resistances of three resistors are given as $R_1 = 10 \Omega$, $R_2 = 20 \Omega$ and $R_3 = 30 \Omega$. Calculate the effective resistance when they are connected in series. Also calculate the current flowing when the combination is connected to a 6V battery.
12. A student performs an experiment to study the magnetic effect of current around a current carrying straight conductor with the help of a magnetic compass. He reports that (i) the degree of deflection of the magnetic compass increases when the compass is moved away from the conductor. (ii) the degree of deflection of the magnetic compass increases when the current through the conductor is increased. Which of the above observations of the student appears to be wrong and why ?
13. How would the reading of voltmeter (V) change if it is connected between C and D ? Justify your answer.

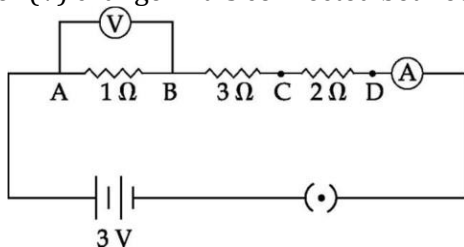

14. (a) Identify the substance oxidized, substance reduced, oxidizing agent and reducing agent in the following reaction : $\text{ZnO} + \text{C} \rightarrow \text{Zn} + \text{CO}$
 (b) Packets of potato chips are flushed with nitrogen gas, why ?
15. A blue colour salt becomes white on heating. Give reason for the above observation. What happens when we add water to the salt which is obtained after heating ? Also write its formula.
16. (a) How does baking soda help to make cakes and bread soft and spongy?
 (b) List the raw materials used for the preparation of baking soda.
 (c) Write chemical equation for its preparation.
17. (a) Which hormone is responsible for the changes noticed in males at puberty ?
 (b) Deficiency of which hormone leads to dwarfism.
 (c) Name the hormone which is injected to a diabetic patient.
18. (a) What is reflex arc ? (b) How do muscle cells move ?
19. Draw a neat diagram of a biogas plant and label (i) inlet of slurry, (ii) digester and (iii) gas outlet.
20. A student performs an experiment with 4 cells and a resistance wire and an ammeter in series and observes that when the number of cells in the circuit is decreased, the value of current through the wire also decreases. Name the law that is involved in the experiment and write its mathematical form. V-I graph for two resistors R₁, R₂ and their series combination are shown in the figure below. Which graph represents the series combination of the other two? Give reason.

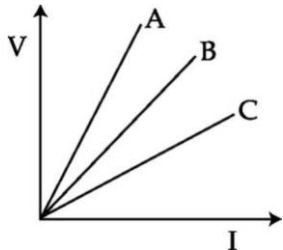

21. For the circuit shown in the diagram calculate:
 (a) the total effective resistance of the circuit (b) the total current in the circuit
 (c) the value of current through 20Ω resistor.

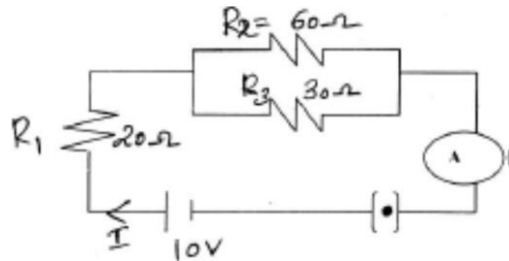

22. What is the function of an earth wire ? Why is it necessary to earth metallic appliances ?
23. (a) What is geothermal energy ? (b) What are the advantages of wind energy.
24. (a) Name the metal which is low in activity series and exists as liquid at room temperature.
 (b) Write the name and formula of its ore. (c) How is the metal extracted from this ore ?
 (d) Write the chemical equation for the reaction involved.

OR

- (i) What causes rusting of iron ? Design an activity to show the conditions needed for iron nails to rust.
 (ii) Why do we paint iron articles ?
25. (a) Draw a neat diagram of excretory system of human beings and label the following :
 (i) Kidney (ii) Ureter (iii) Urinary Bladder (iv) Urethra
 (b) How is urine produced. (c) Name two excretory products other than O₂ and CO₂ in plants.

OR

- (a) Draw diagram to show the nutrition in amoeba and label the part used for this purpose.
 Mention any other purpose served by this part other than nutrition.
 (b) Name the glands associated with digestion of starch in human digestive tract and mention their role.
 (c) How is required pH maintained in the stomach and small intestine
26. (a) A coil of insulated copper wire is connected to a galvanometer. What will happen if a bar magnet is :
 (i) pushed into the coil with its north pole entering first ? (ii) withdrawn from inside the coil ?

(iii) held stationary inside the coil ?

(b) Name the above phenomenon and mention the name of the scientist who discovered it.

State the law that relates the direction of current in the coil with the direction of motion of the magnet.

OR

Consider a circular loop of wire lying in the plane of the paper. Let the current pass through the loop clockwise. With the help of a diagram explain how the direction of the magnetic field can be determined inside and outside the loop.

(a) Name the law used to find the direction of magnetic field.

(b) Draw a diagram to represent a uniform magnetic field in a given region.

(c) List two properties of magnetic field lines.

27. (a) Name the enzyme present in saliva. Why is it important ? (b) What is emulsification ?

(c) Name the substance that is oxidized in the body during respiration.

(d) Why are lungs divided into very small sac-like structures ?

OR

(a) Draw a neat diagram of human respiratory system and label the parts and label 9 parts in it.

(b) What are the end products of digestion of fat and protein in human beings ?

SECTION –B

28. A student was observing a pH chart. He observed that the two colours at the extreme ends of the pH chart are :

(a) red and green (b) red and blue (c) green and blue (d) orange and green pH

29. When a drop of an unknown solution X is placed on a strip of pH paper, a deep blue colour is produced. This solution should be –

(a) NaOH (b) Lemon juice (c) Water (d) HCl

30. On adding dilute hydrochloric acid to granulated zinc placed in a test tube, a student would observe that :

(a) the surface of the metal turns shining. (b) the reaction mixture turns milky.
(c) the reaction mixture gives odour of chlorine. (d) a colourless and odourless gas evolves with bubbles.

31. When sodium sulphate solution and barium chloride solution are mixed together, the colour of precipitate formed is :

(a) Yellow (b) Green (c) White (d) Red

32. While doing an experiment a student observed that the blue colour of the aqueous copper sulphate solution was changed to pale green by immersing a metal rod in it. The metal of the rod used by the student is :

(a) iron (b) zinc (c) silver (d) aluminium

33. For the circuit arrangement, shown above the student would observe

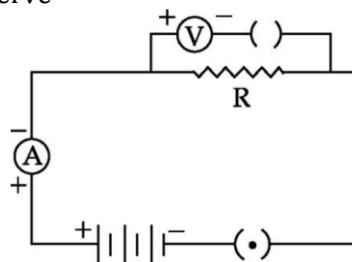

(a) some reading in both the ammeter and the voltmeter

(b) no reading in either the ammeter or the voltmeter

(c) some reading in the ammeter but no reading in the voltmeter

(d) some reading in the voltmeter but no reading in ammeter

34. In the experiment to study the dependence of current on potential difference across a resistor, a student obtained a graph as shown in the diagram. The value of resistance of the resistor is :

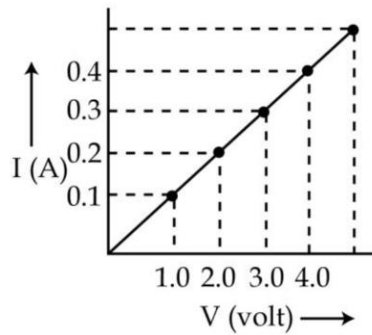

- (a) 0.1Ω (b) 1.0Ω (c) 10Ω (d) 100Ω

35. The current flowing through a conductor and the potential difference across its two ends are as per readings of the ammeter and the voltmeter shown below. The resistance of the conductor would be :

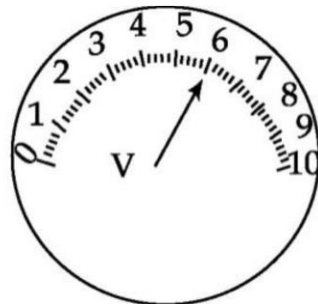
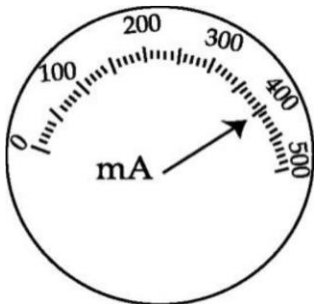

- (a) 0.15Ω (b) 1.5Ω (c) 15.0Ω (d) 150.0Ω

36. The resistors R_1 and R_2 are connected in :

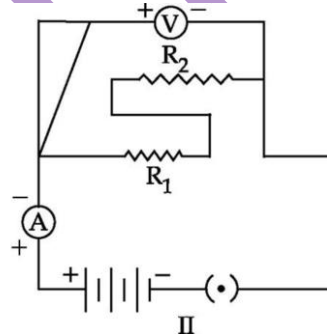
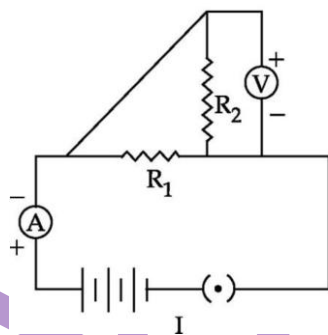

- (a) parallel in both circuits. (b) series in both circuits.
(c) parallel in circuit I and in series in circuit II. (d) series in circuit I and in parallel in circuit II.

37. Study the two circuits circuit I and circuit II shown below. In circuit I, ammeter reads current I_1 and voltmeter reads voltage V_1 . In circuit II, ammeter reads current I_2 and voltmeter reads voltage V_2 . Which one of the following is the correct statement about the ammeter and voltmeter readings ?

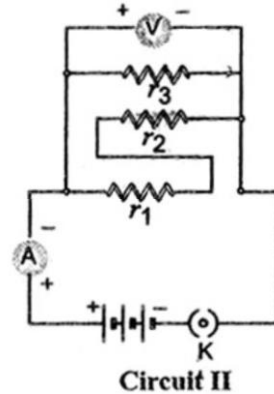
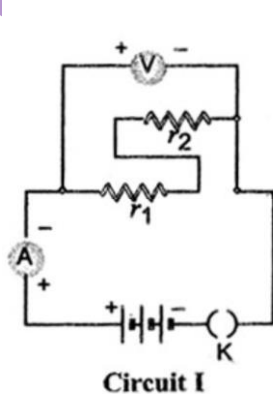

- (a) $I_1 > I_2; V_1 = V_2$ (b) $I_1 < I_2; V_1 = V_2$ (c) $I_1 > I_2; V_1 > V_2$ (d) $I_1 < I_2; V_1 < V_2$

38. To make the plant free of starch, it is kept :

- (a) in darkness for 72 hours. (b) in a room, but with lights on at night only.
(c) under the shade of a tree. (d) covered with coloured polythene in a shady place.

39. During the experiment to show that plants do photosynthesis, the destarched leaf is boiled in alcohol. Once boiling is completed,
- (a) alcohol remains colourless (b) leaf remains greenish
 (c) alcohol turns greenish and leaf becomes colourless (d) no visible change occur
40. While preparing a temporary stained mount of a leaf epidermal peel, the extra stain is removed by :
- (a) washing with water (b) washing with calcium chloride
 (c) soaking with filter paper (d) absorbing with cotton wool
41. A student focused the leaf epidermal peel under a low power microscope, but he could not see all the parts. He should :
- (a) use the coarse adjustment knob again to focus the slide
 (b) use the fine adjustment knob to increase magnification
 (c) focus under high power using coarse adjustment knob
 (d) focus under high power using fine adjustment knob
42. After performing the experiment to show that germinating seeds give out carbon dioxide during respiration, students drew the following labeled diagrams. The correct labelled diagram is

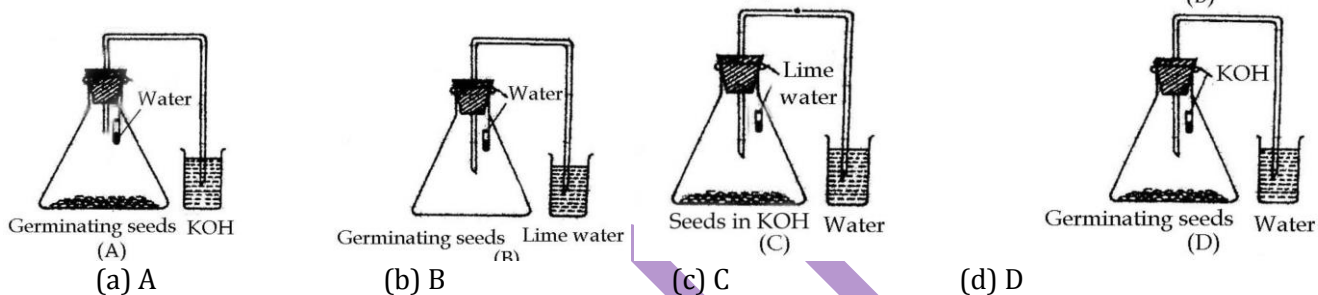

43. Before setting up an experiment to show that seeds release CO₂ during respiration, the seeds should be :
- (a) dried completely. (b) boiled to make them soft.
 (c) soaked in vinegar. (d) kept moist till they germinate.

ALL THE BEST

Contact : Jayant Sharma (09414537474)
 B - 596/97, D.D.A. Colony
 Chowkhandi, New Delhi - 18