

## PART II : PHYSICS

### SECTION – I (Total Marks : 24)

(Single Correct Answer Type)

This section contains **8 multiple choice questions**. Each question has four choices (A), (B), (C) and (D) out of which **ONLY ONE** is correct.

21. A light ray traveling in glass medium is incident on glass-air interface at an angle of incidence  $\theta$ . The reflected ( R ) and transmitted ( T ) intensities, both as function of  $\theta$ , are plotted. The correct sketch is

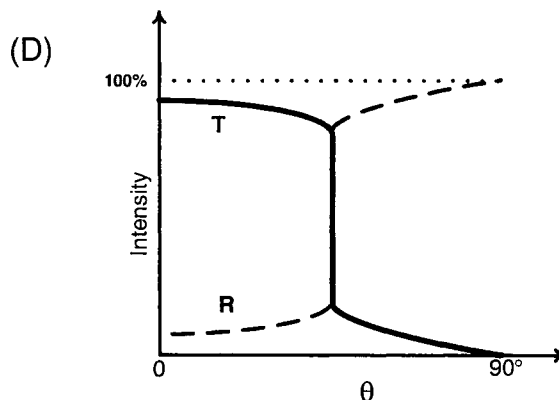
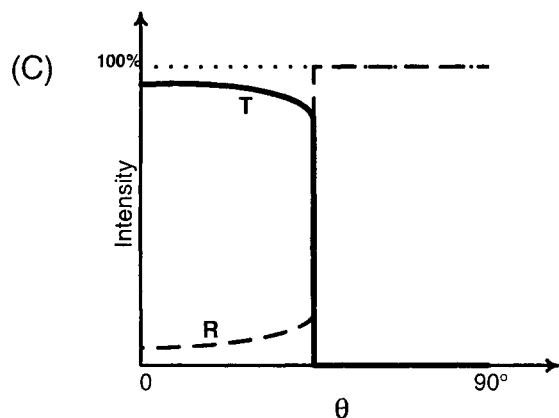
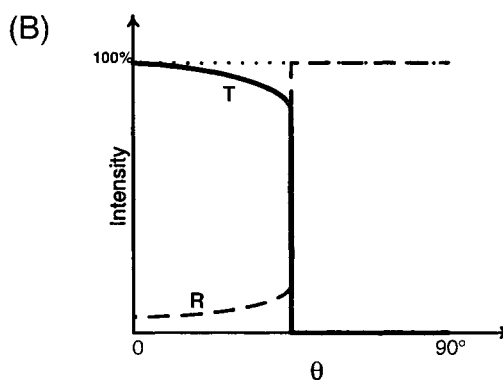
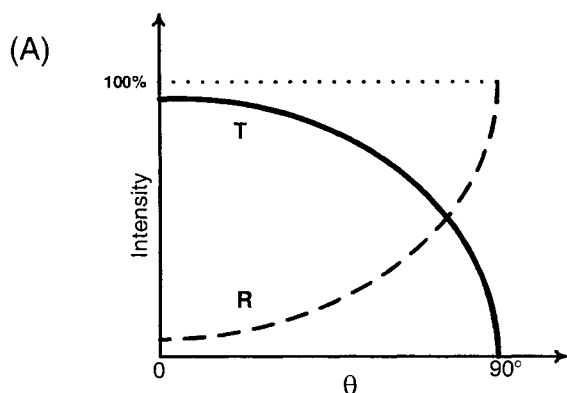

**ANSWER : C**

22. A satellite is moving with a constant speed ' $V$ ' in a circular orbit about the earth. An object of mass ' $m$ ' is ejected from the satellite such that it just escapes from the gravitational pull of the earth. At the time of its ejection, the kinetic energy of the object is

(A)  $\frac{1}{2}mV^2$       (B)  $mV^2$       (C)  $\frac{3}{2}mV^2$       (D)  $2mV^2$

**ANSWER : B**

23. A long insulated copper wire is closely wound as a spiral of 'N' turns. The spiral has inner radius 'a' and outer radius 'b'. The spiral lies in the X-Y plane and a steady current 'I' flows through the wire. The Z-component of the magnetic field at the center of the spiral is

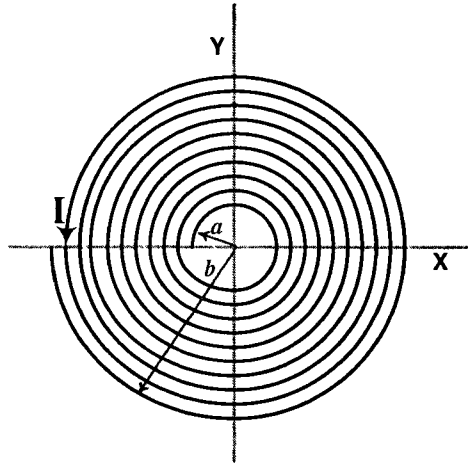

- (A)  $\frac{\mu_0 N I}{2(b-a)} \ln\left(\frac{b}{a}\right)$                       (B)  $\frac{\mu_0 N I}{2(b-a)} \ln\left(\frac{b+a}{b-a}\right)$   
 (C)  $\frac{\mu_0 N I}{2b} \ln\left(\frac{b}{a}\right)$                       (D)  $\frac{\mu_0 N I}{2b} \ln\left(\frac{b+a}{b-a}\right)$

**ANSWER : A**

24. A point mass is subjected to two simultaneous sinusoidal displacements in x-direction,  $x_1(t) = A \sin \omega t$  and  $x_2(t) = A \sin\left(\omega t + \frac{2\pi}{3}\right)$ . Adding a third sinusoidal displacement  $x_3(t) = B \sin(\omega t + \phi)$  brings the mass to a complete rest. The values of B and  $\phi$  are

- (A)  $\sqrt{2} A, \frac{3\pi}{4}$       (B)  $A, \frac{4\pi}{3}$       (C)  $\sqrt{3} A, \frac{5\pi}{6}$       (D)  $A, \frac{\pi}{3}$

**ANSWER : B**

25. Which of the field patterns given below is valid for electric field as well as for magnetic field?

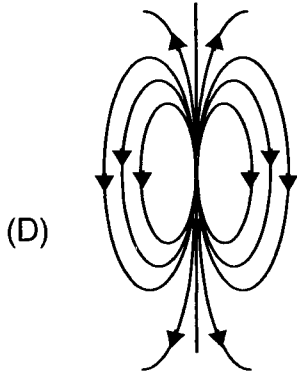
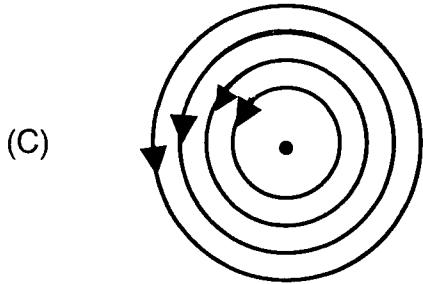
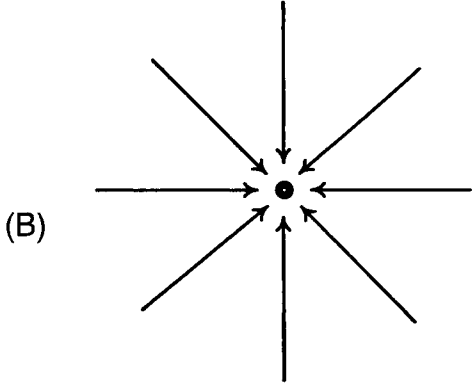
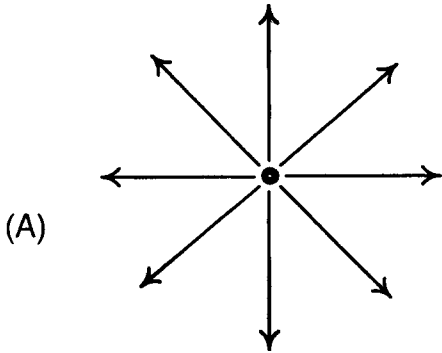

**ANSWER : C**

26. A ball of mass 0.2 kg rests on a vertical post of height 5 m. A bullet of mass 0.01 kg, traveling with a velocity  $V$  m/s in a horizontal direction, hits the centre of the ball. After the collision, the ball and bullet travel independently. The ball hits the ground at a distance of 20 m and the bullet at a distance of 100 m from the foot of the post. The initial velocity  $V$  of the bullet is

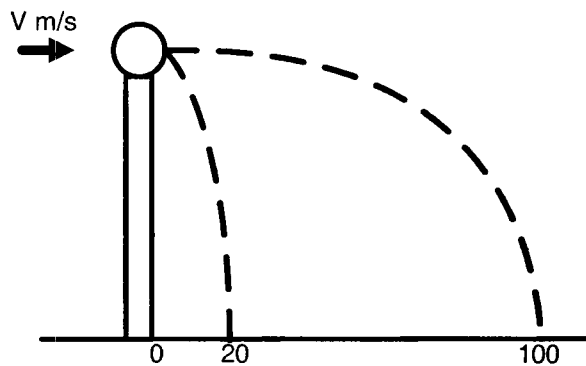

- (A) 250 m/s      (B)  $250\sqrt{2}$  m/s      (C) 400 m/s      (D) 500 m/s

**ANSWER : D**

27. The density of a solid ball is to be determined in an experiment. The diameter of the ball is measured with a screw gauge, whose pitch is 0.5 mm and there are 50 divisions on the circular scale. The reading on the main scale is 2.5 mm and that on the circular scale is 20 divisions. If the measured mass of the ball has a relative error of 2%, the relative percentage error in the density is

- (A) 0.9%      (B) 2.4%      (C) 3.1%      (D) 4.2%

**ANSWER : C**

28. A wooden block performs SHM on a frictionless surface with frequency,  $\nu_0$ . The block carries a charge  $+Q$  on its surface. If now a uniform electric field  $\vec{E}$  is switched-on as shown, then the SHM of the block will be

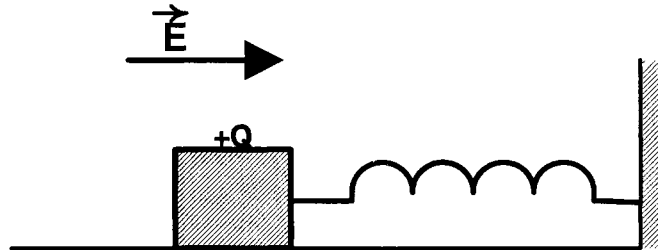

- (A) of the same frequency and with shifted mean position.
- (B) of the same frequency and with the same mean position.
- (C) of changed frequency and with shifted mean position.
- (D) of changed frequency and with the same mean position.

**ANSWER : A**

## SECTION – II (Total Marks : 16)

(Multiple Correct Answer(s) Type)

This section contains **4 multiple choice questions**. Each question has four choices (A), (B), (C) and (D) out of which **ONE or MORE** may be correct.

29. Two solid spheres A and B of equal volumes but of different densities  $d_A$  and  $d_B$  are connected by a string. They are fully immersed in a fluid of density  $d_F$ . They get arranged into an equilibrium state as shown in the figure with a tension in the string. The arrangement is possible only if

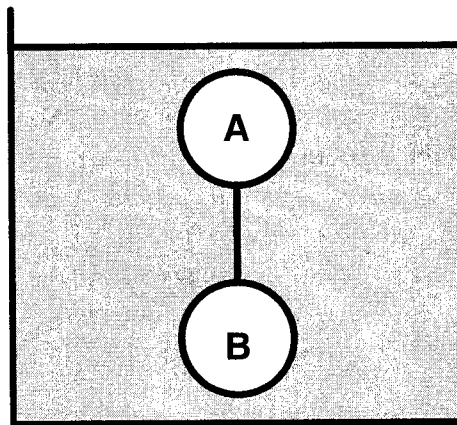

- (A)  $d_A < d_F$  (B)  $d_B > d_F$   
 (C)  $d_A > d_F$  (D)  $d_A + d_B = 2 d_F$

**ANSWER : ABD**

30. A series R-C circuit is connected to AC voltage source. Consider two cases; (A) when C is without a dielectric medium and (B) when C is filled with dielectric of constant 4. The current  $I_R$  through the resistor and voltage  $V_C$  across the capacitor are compared in the two cases. Which of the following is/are true?

- (A)  $I_R^A > I_R^B$  (B)  $I_R^A < I_R^B$   
 (C)  $V_C^A > V_C^B$  (D)  $V_C^A < V_C^B$

**ANSWER : BC**

31. Which of the following statement(s) is/are correct?
- (A) If the electric field due to a point charge varies as  $r^{-2.5}$  instead of  $r^{-2}$ , then the Gauss law will still be valid.
  - (B) The Gauss law can be used to calculate the field distribution around an electric dipole.
  - (C) If the electric field between two point charges is zero somewhere, then the sign of the two charges is the same.
  - (D) The work done by the external force in moving a unit positive charge from point A at potential  $V_A$  to point B at potential  $V_B$  is  $(V_B - V_A)$ .

**ANSWER : CD**

32. A thin ring of mass 2 kg and radius 0.5 m is rolling without slipping on a horizontal plane with velocity 1 m/s. A small ball of mass 0.1 kg, moving with velocity 20 m/s in the opposite direction, hits the ring at a height of 0.75 m and goes vertically up with velocity 10 m/s. Immediately after the collision

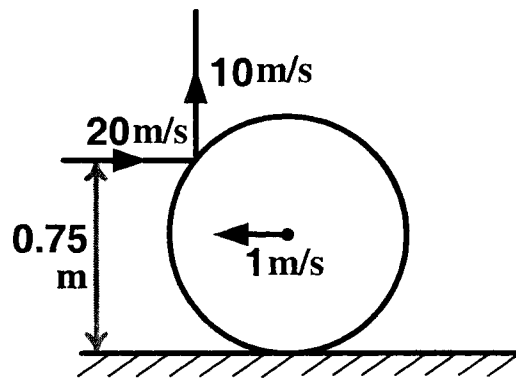

- (A) the ring has pure rotation about its stationary CM.
- (B) the ring comes to a complete stop.
- (C) friction between the ring and the ground is to the left.
- (D) there is no friction between the ring and the ground.

**ANSWER : A OR AC**

## SECTION – III (Total Marks : 24)

(Integer Answer Type)

This section contains 6 questions. The answer to each of the questions is a **single-digit integer**, ranging from 0 to 9. The bubble corresponding to the correct answer is to be darkened in the ORS.

33. A train is moving along a straight line with a constant acceleration ' $\alpha$ '. A boy standing in the train throws a ball forward with a speed of 10 m/s, at an angle of  $60^\circ$  to the horizontal. The boy has to move forward by 1.15 m inside the train to catch the ball back at the initial height. The acceleration of the train, in  $\text{m/s}^2$ , is

**ANSWER : 5**

34. A block of mass 0.18 kg is attached to a spring of force-constant 2 N/m. The coefficient of friction between the block and the floor is 0.1. Initially the block is at rest and the spring is un-stretched. An impulse is given to the block as shown in the figure. The block slides a distance of 0.06 m and comes to rest for the first time. The initial velocity of the block in m/s is  $V = N/10$ . Then N is

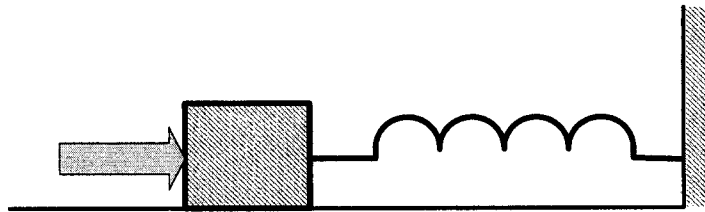
**ANSWER : 4**

35. Two batteries of different emfs and different internal resistances are connected as shown. The voltage across AB in volts is

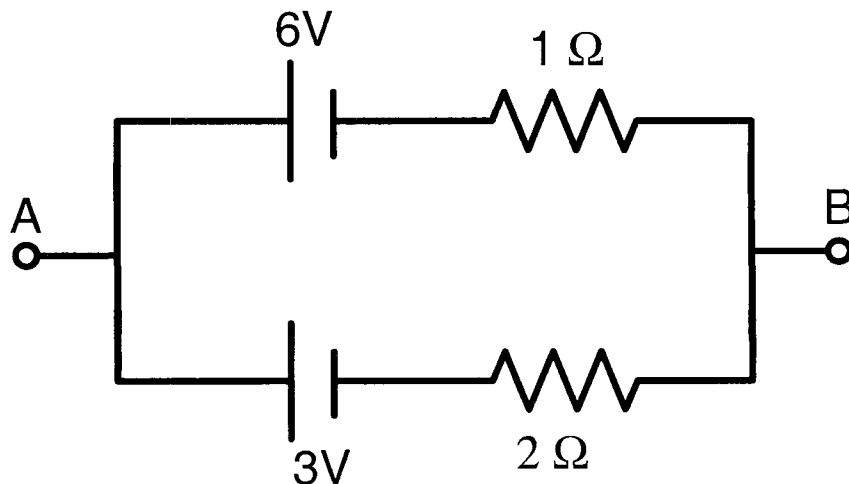
**ANSWER : 5**



36. Water (with refractive index =  $\frac{4}{3}$ ) in a tank is 18 cm deep. Oil of refractive index  $\frac{7}{4}$  lies on water making a convex surface of radius of curvature 'R = 6 cm' as shown. Consider oil to act as a thin lens. An object 'S' is placed 24 cm above water surface. The location of its image is at 'x' cm above the bottom of the tank. Then 'x' is

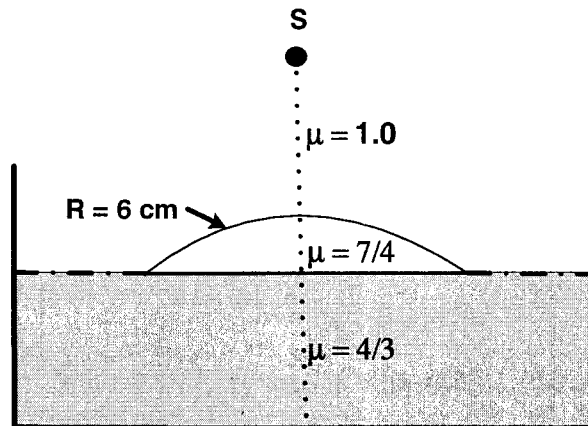

**ANSWER : 2**

37. A series R-C combination is connected to an AC voltage of angular frequency  $\omega = 500$  radian/s. If the impedance of the R-C circuit is  $R\sqrt{1.25}$ , the time constant (in millisecond) of the circuit is

**ANSWER : 4**

38. A silver sphere of radius 1 cm and work function 4.7 eV is suspended from an insulating thread in free-space. It is under continuous illumination of 200 nm wavelength light. As photoelectrons are emitted, the sphere gets charged and acquires a potential. The maximum number of photoelectrons emitted from the sphere is  $A \times 10^Z$  (where  $1 < A < 10$ ). The value of 'Z' is

**ANSWER : 7**

### SECTION – IV (Total Marks : 16)

(Matrix-Match Type)

This section contains **2 questions**. Each question has **four statements** (A, B, C and D) given in **Column I** and **five statements** (p, q, r, s and t) in **Column II**. Any given statement in Column I can have correct matching with **ONE** or **MORE** statement(s) given in Column II. For example, if for a given question, statement B matches with the statements given in q and r, then for the particular question, against statement B, darken the bubbles corresponding to q and r in the ORS.

39. One mole of a monatomic ideal gas is taken through a cycle ABCDA as shown in the P-V diagram. **Column II** gives the characteristics involved in the cycle. Match them with each of the processes given in **Column I**.

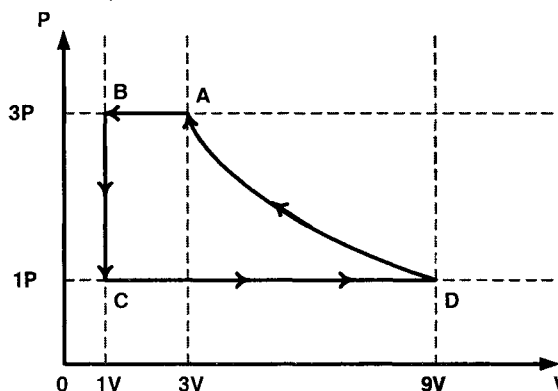

Column I	Column II
(A) Process A → B	(p) Internal energy decreases.
(B) Process B → C	(q) Internal energy increases.
(C) Process C → D	(r) Heat is lost.
(D) Process D → A	(s) Heat is gained.
	(t) Work is done on the gas.

**ANSWER A : p, r and t**  
**B : p and r**  
**C : q and s**  
**D : r and t**

40. **Column I** shows four systems, each of the same length  $L$ , for producing standing waves. The lowest possible natural frequency of a system is called its fundamental frequency, whose wavelength is denoted as  $\lambda_f$ . Match each system with statements given in **Column II** describing the nature and wavelength of the standing waves.

**Column I**

- (A) Pipe closed at one end

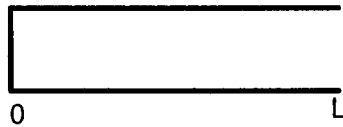

- (B) Pipe open at both ends

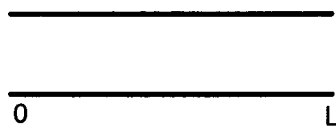

- (C) Stretched wire clamped at both ends

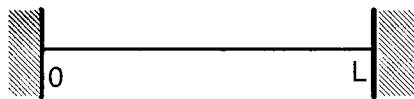

- (D) Stretched wire clamped at both ends and at mid-point

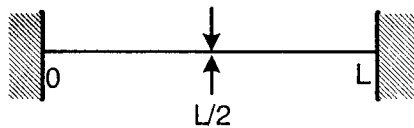

**Column II**

(p) Longitudinal waves

(q) Transverse waves

(r)  $\lambda_f = L$

(s)  $\lambda_f = 2L$

(t)  $\lambda_f = 4L$

**ANSWER A : p and t**

**B : p and s**

**C : q and s**

**D : q and r**